

Spritzseite X

Injection side (Moving platen)
Cote injection
Lado de inyeccion

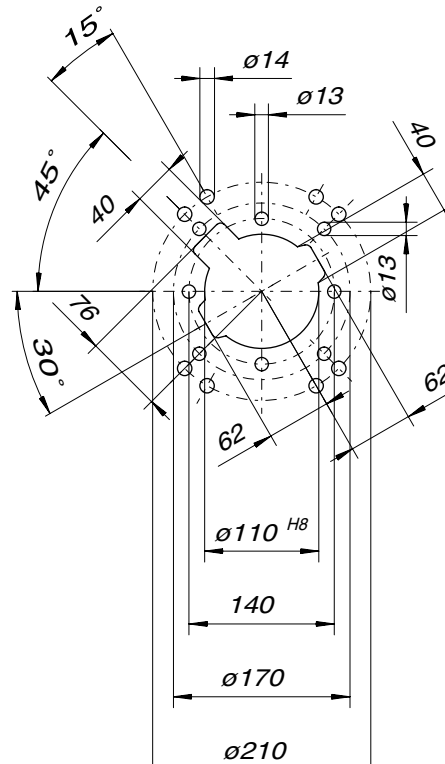
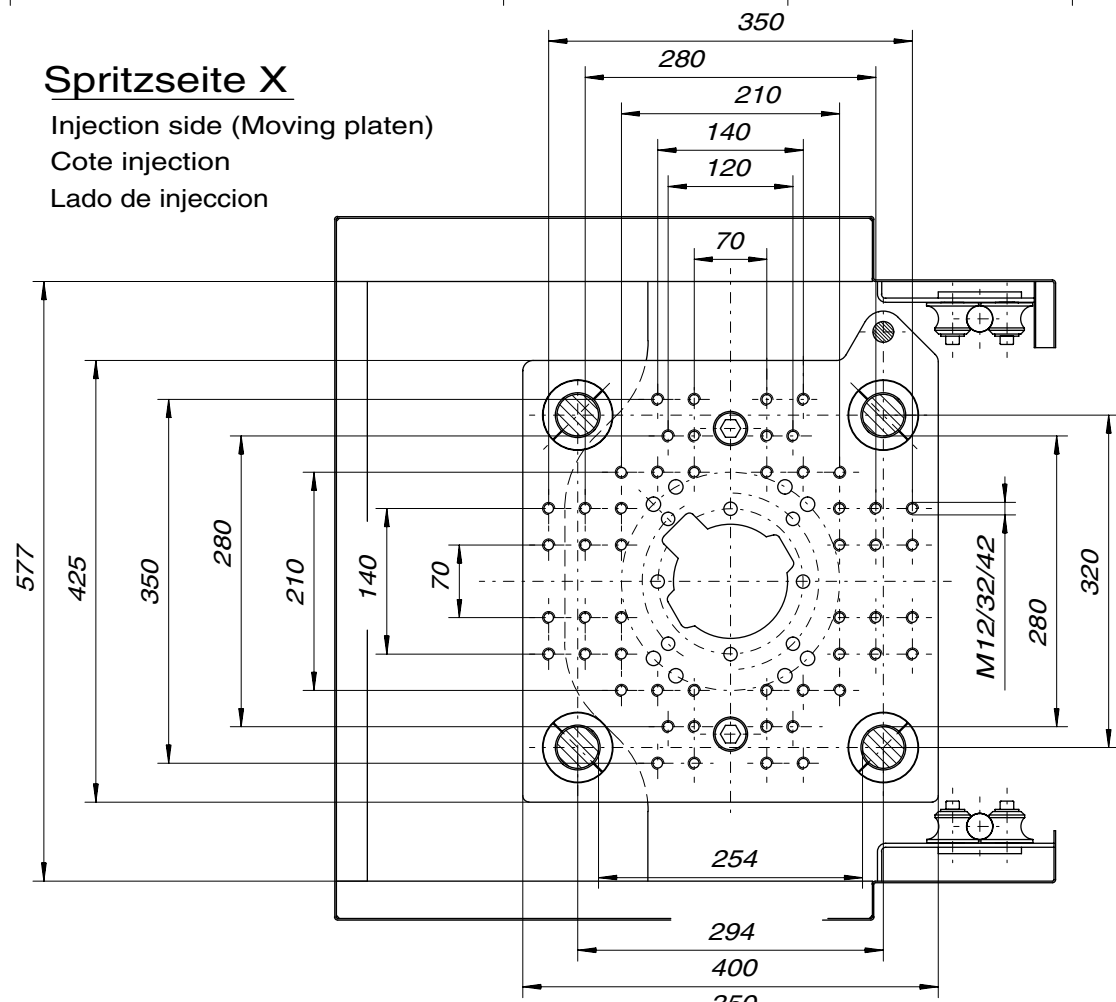

Hydr.Verschußdüse max.30mm
Hydr.shut off nozzle max.30mm
Buse hydr.de fermeture max.30mm
Tobera de obturador de aguja accionada hidraulicamente max.30mm

Offene Düse max. 35mm
Open nozzle max.35mm
Buse ouverte max.35mm
Boquilla abierta max.35mm

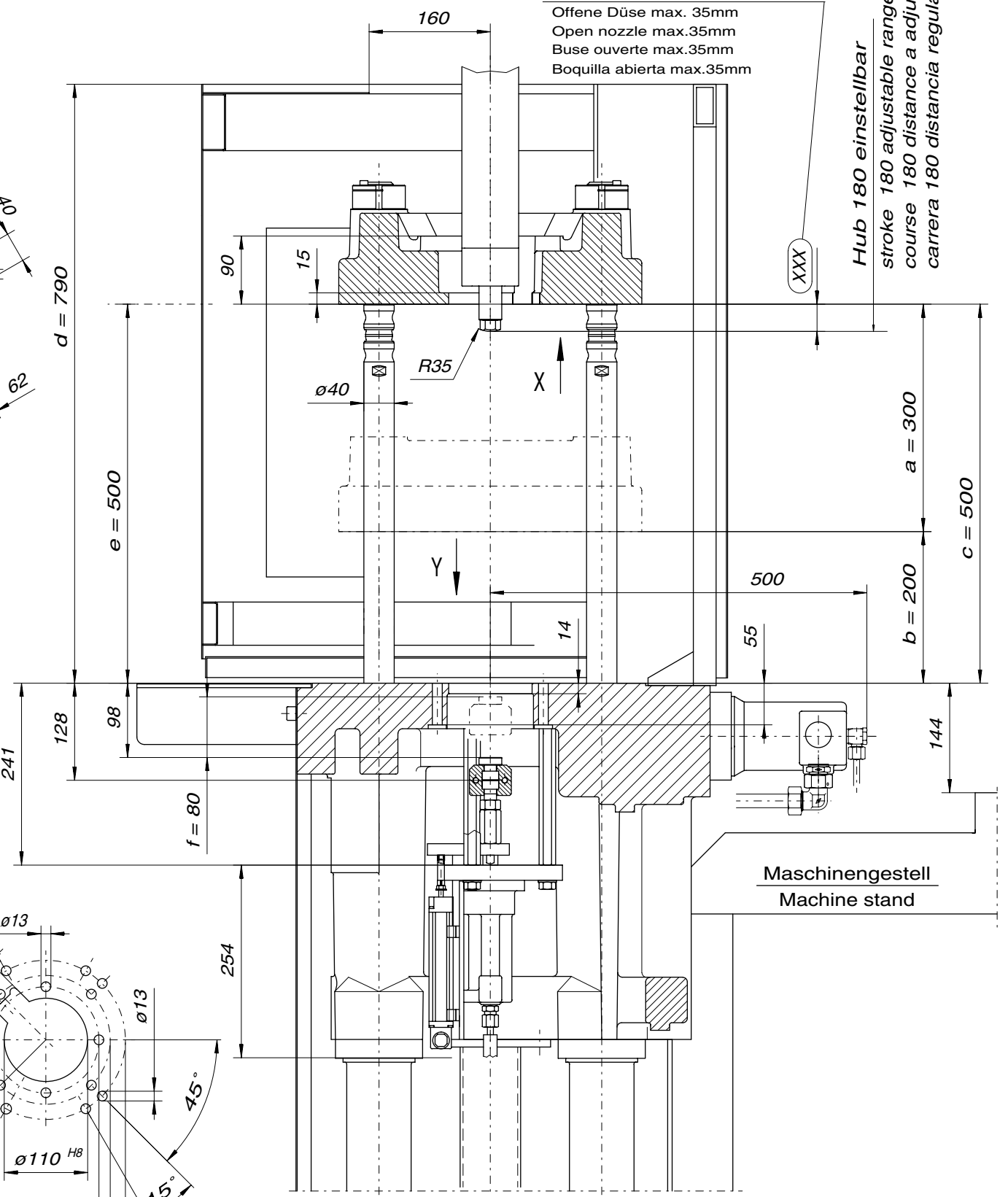

Schließseite Y

Closing side (Fixed platen)
Cote fermeture
Lado de cierre

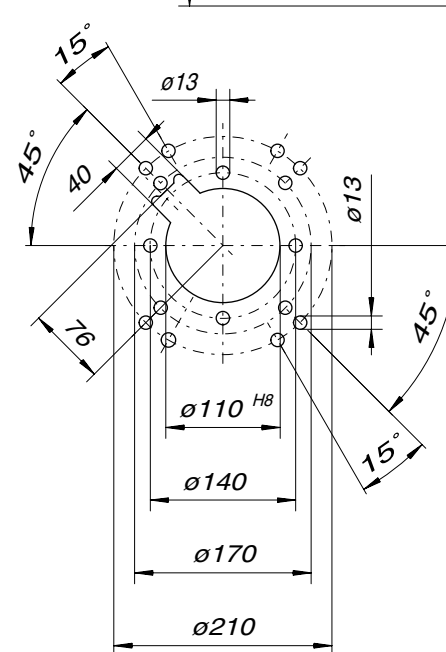
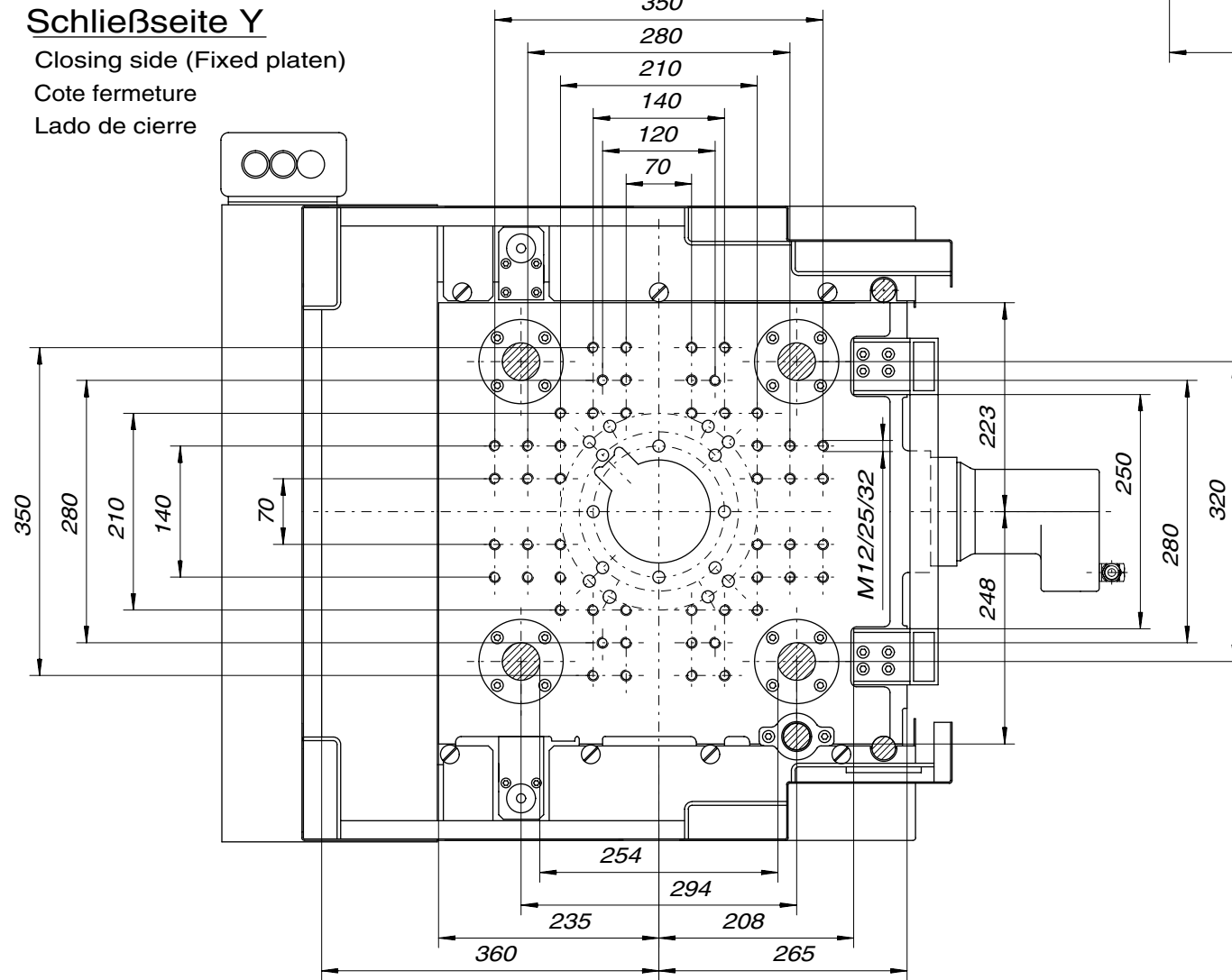

Hub 180 einstellbar
stroke 180 adjustable range
course 180 distance a adjuster
carrera 180 distancia regulable

Maschinengestell
Machine stand

a=Hub	Stroke	Course	Recorrido
b=Formhöhe	Mould height	Hauteur du moule	Altura del molde
c=Schutzhöhe + Hub	Mould height+stroke	Hauteur du moule + course	Altura del molde + recorrido
d=Schutzhaube	Safety gate	Grille de protection	Cofia protectora
e=Schutzhaubenhub	Safety gate stroke	Course de grille de protection	Recorrido de cofia protectora
f=Auswerferhub	Ejector stroke	Course de ejecteur	Recorrido de eyector

Benennung	Einbaumaße BOY 35 VV	Benennung	DR.BÖY GmbH & Co.KG
Zeichnungsnummer	167375-0 c	Verwendung bei Maschine	BOY 35 VV
Gezeichnet	12.03	Geprüft	25.02
Gezeichnet	12.03	Geprüft	25.02
Für diese Zeichnung behalten wir uns alle Rechte vor. DIN 34			